

Temperature Sensor 85026 Series

GENERAL DESCRIPTION

The patented* No. 85026-Series Temperature Sensor contains a two-position valve operated by temperature variations around the integral sensing bulb. It is used to vent or block a pneumatic signal when the setpoint is reached, depending upon the model in use. The sensor has provisions for piped vent operation and is available with a stainless steel thermowell.

In the event the liquid-filled charge is lost, the sensor is constructed to open the valve, both in the direct-acting** and reverse-acting** versions.

The control pressure must be provided through a .032" (.8 mm) diameter or smaller orifice for correct operation.

*Patent No. 3,937,244

**In normal operation the direct-acting sensor vents on increasing temperature and the reverse-acting sensor closes vent on increasing temperature.



SPECIFICATIONS

Materials:

Valve body and nameplate Anodized Aluminum
Bulb Brass and S.S. with pressed ball seal
Bushing (or Thermowell if specified) Stainless steel
O-Rings Fluorocarbon and Silicon rubber
Screws, springs and locknut Stainless steel
Valve parts Stainless steel and anodized aluminum

Setpoint Range: 0 to 400° F. (-18 to 205° C.)

Element Exposure Range: . -40 to 450° F. (-40 to 230° C.)

Body Exposure Range: -40 to 300° F. (-40 to 150° C.)

Max. Element Temperature: 450° F. (230° C.)

Max. Ambient Temperature: 300° F. (150° C.)

Max. Pressure on Bulb:

500 psi @ 200° F. (35 bar @ 93° C.)

200 psi @ 400° F. (14 bar @ 205° C.)

Max. Pressure on Thermowell:

85031-A1 Kit (with 36167-A1 Thermowell) -

5000 psi @ 400° F. (345 bar @ 205° C.)

85031-A2 Kit (with 36167-A2 Thermowell)

10,000 psi @ 400° F. (690 bar @ 205° C.)

Supply Pressure: 20 to 60 psig (1.4 to 4.1 bar)

Max. Pressure: 60 psig (4.1 bar)

CAUTION: DO NOT EXCEED MAXIMUM TEMP./PRESS. RATINGS

Control Medium: Air, Natural Gas, Nitrogen, CO₂

Filtration (Minimum): 25 microns

Moisture (Pressure Dewpoint): 15° F. (8° C.) less than ambient temperature

Oil Content (Natural Base): 5 ppm

Oil Content (Synthetic Base): 0 ppm

NOTE: These are suggested minimums for control medium quality. For operation under more adverse conditions, consult factory.



85026-A1
 Vents on Increase
 (Direct Acting)

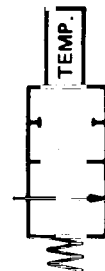

85026-B1
 Closes Vent on Increase
 (Reverse Acting)

J.I.C. SYMBOL

ORDERING INFORMATION

Specify:

- (1) Model Number
- (2) Set Point (if desired)
- (3) Special Features (such as Thermowell)
- (4) Tagging

Reset Differential: .6 to 16° F. (3.3 to 9° C.) non-adjustable
Repeatability:..... ±5° F. (2.8° C.)
Mounting Dimensions: See Figure 1
Approximate Shipping Weight:
Without Thermowell 1-1/4 lbs. (.6 Kg)
With 85031-A1 Thermowell Kit 1-1/2 lbs. (.7 Kg)
With 85031-A2 Thermowell Kit 2-1/8 lbs. (1 Kg)

Models Available:

85026-X0XXX

| 3rd & 4th DIGIT | BODY MATERIAL |
|-----------------|-----------------|
| 01 | Aluminum |
| 19 | Stainless Steel |

| 2nd DIGIT | INSTALLATION ACCESSORIES |
|-----------|---|
| 0 | Stainless St. bushing with 3/4" - 14 NPT thread |
| 1 | Stainless Steel thermowell and Beryllium Copper sleeve with 3/4" - 14 NPT thread. Rating: 5,000 psi max. @ 400° F. |
| 2 | High Pressure Stainless Steel Thermowell and Beryllium Copper sleeve with 1" - 11-1/2 NPT thread. Rating: 10,000 psi Max. @ 400° F. |
| 3 | Replacement temperature sensor without installation accessories |

| SUFFIX LETTER | TYPE OF ACTION |
|---------------|--|
| A | Direct Acting - Vents on increase |
| B | Reverse Acting - Closes vent on increase |

NOTE: If St. St. thermowell is required, specify No. 85031-A1 or A2 Thermowell Kit.

INSTALLATION

NOTE: Handle instrument with care to avoid damage to sensing element.

Bulb Location - Correct location is the most important detail of sensor installation. The bulb should be installed at a point of true representative temperature in good circulation with maximum insertion depth. If a thermometer is used, its sensing element should be installed adjacent to the bulb.

Mounting: The 85026-Series temperature sensor may be mounted in any position, but vertical (upright) is recommended. Vent openings should have fittings installed turned down. Care should be taken to prevent foreign matter from entering the valve ports during installation.

If the sensor is out of doors or in any way exposed to water during cleaning, etc., it should be mounted in a position which will prevent water entry into the valve housing. Water trapped in the housing will impair operation and could freeze during winter months. The 1/8" - 27 NPT connections can be used for piped vent operation if gas is used as the operating medium.

Unless ordered with a thermowell, each sensor model is equipped with a bushing with 3/4" - 14 NPT external threads. CAUTION: Do NOT use pipe wrench, channel locks, etc., on valve body when tightening into bushing or thermowell.

To mount sensor, loosen jam nut (see Fig. 5, detail 9) and remove bushing. Install bushing in desired location. Place sensor in bushing, positioning it with the desired port orientation. Tighten jam nut.

Connections (See Figure 1): The sensor has two 1 / 8" - 27 NPT connections used for control pressure (port "IN") and piped vent operation (port "V"). Control pressure must be provided through a .032" (.8 mm) diameter or smaller orifice.

CAUTION: The piped vent from the sensor cannot be used as a supply source for any other equipment. If sensor vent is restricted in this manner, faulty operation will result.

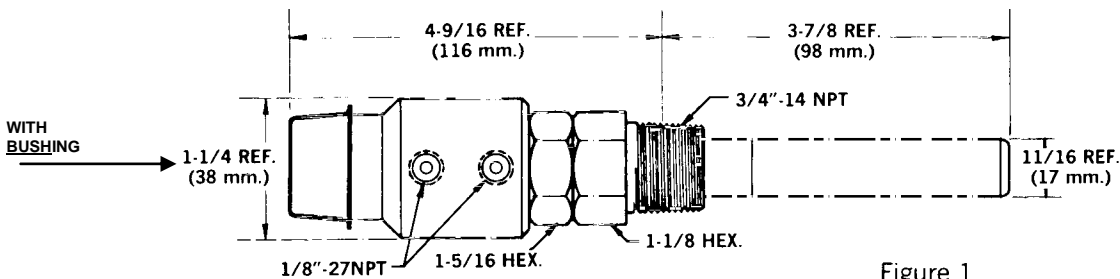
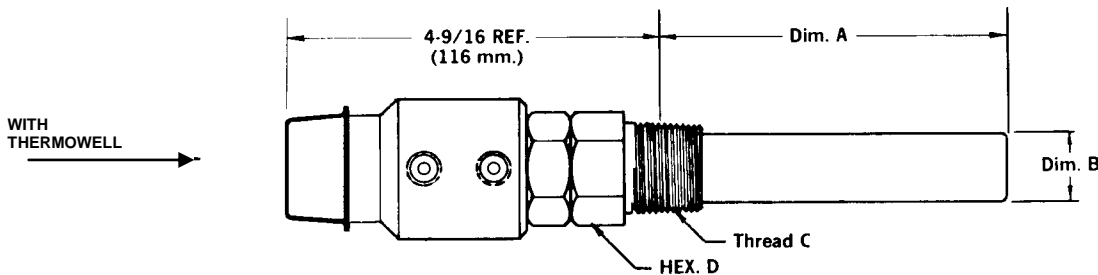

Figure 1



| Thermowell | Dim. A | Dim B. | Thread C | Hex. D |
|------------|-------------------|-------------|----------------|--------|
| 85031-A1 | 4 - 3/16 (106mm) | 7/8 (22mm) | 3/4-14 NPT | 1-1/8 |
| 85031-A2 | 4 - 31/64 (114mm) | 1.10 (28mm) | 1 - 11 -1/2NPT | 1-3/8 |

Tubing and fittings used to connect the sensor must be free of chips, dirt, moisture, or other foreign matter.

It is recommended that a non-hardening, "anti-seize" type thread compound be applied to the second or third male thread in moderate amount. Do not allow any compound to be deposited inside the sensor.

Thermowell (See Figure 1): CAUTION: When using the socket kit, the bushing and O-ring (See Figure 5, details 17 and 18) are not used.

The thermowell is used to protect the bulb from corrosion, high pressure, etc., and to permit removing the sensor from the vessel without draining the system. Install the thermowell as described for bushing above.

A sleeve of heat-conductive material is used with the thermowell to reduce the loss in rate of response due to the additional metal thickness and the effect of the dead air space between the bulb and thermowell.

To install the bulb in the thermowell, place a small portion of the sensor bulb in the sleeve while placing the other end of the sleeve inside the thermowell. Feed the sleeve into the thermowell bottom as the bulb is pushed into the thermowell.

OPERATION (See Figure 2)

The area between the bellows and the outer wall of the bulb is filled with a charging fluid. As the temperature around the bulb increases, this fluid will expand and force

the bellows to compress and carry the stem upward against the valve spring and ball.

In direct-acting sensors the rising stem will lift the valve ball off seat and open the control signal pressure to vent.

In reverse-acting sensors the rising stem will push the valve ball against seat and close off the control signal pressure from vent.

As the temperature around the bulb decreases, the fluid will contract and allow the bellows to extend as the valve spring pushes against the stem through the valve ball, forcing it back down. As the stem retracts, the valve spring will push the valve ball on seat in the direct-acting sensor and block the vent port. In the reverse-acting sensor the valve spring will push the valve ball off seat and open the control pressure to vent.

In both the direct- and reverse-acting sensors a loss of charging fluid in the bulb will cause the sensor to vent the control signal. In the direct-acting sensor, the bellows will extend, as the charge leaks out, until the two steel balls that lock the stem in the tube fall out of place and release the spring-loaded stem. The stem will be forced upward by the spring and will lift the valve ball off seat allowing the sensor to vent. In the reverse-acting sensor there are no steel balls so that, as the bellows extends on loss of charge, the valve spring will push the valve ball off seat against the receding stem.

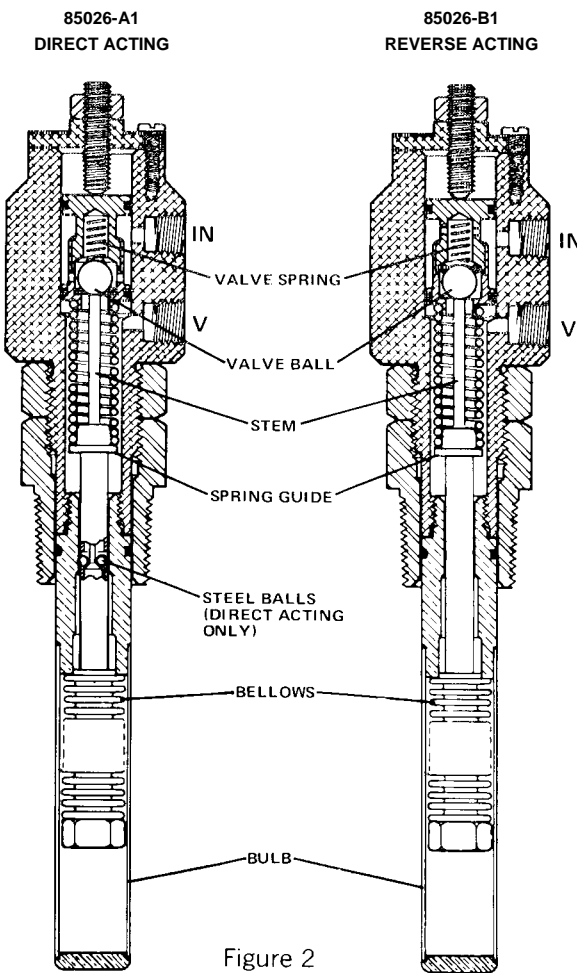

Figure 2

SETPOINT ADJUSTMENT AND CALIBRATION (Refer to Figure 3)

CAUTION: Read adjustment instructions completely before beginning calibration or connecting test equipment. Do not clamp sensor in a vise or similar tool while making calibration adjustments. Distortion of the sensor will cause a shift in setpoint or impair operation.

GENERAL:

WARNING: Care must be exercised to prevent the control pressure from venting in a manner which would be injurious to personnel.

The setpoint may be adjusted within the limits of the temperature range and control pressure in the following manner:

1. With control pressure off, connect test equipment as shown in Fig. 3.
2. Remove the protective cover on top of the sensor and loosen the locknut. Loosen the setpoint screw counterclockwise until there is no spring load. This can be checked by turning the setpoint screw IN and OUT with the fingers to determine where the spring stops.
3. Allow the sensor to stabilize in a well agitated bath at the desired setpoint.
4. Apply the desired operating control pressure - maximum 60 psig (4.1 bar) - at the "IN" port through a .032" (.8 mm) diameter orifice or smaller. The supply pressure and orifice size MUST be the same as that used during operation. The direct-acting* version should be closed and the reverse-acting* version open at this time.

* In normal operation the direct acting sensor vents on increasing temperature and the reverse acting sensor closes vent on increasing temperature.

DIRECT ACTING (vents on increasing temperature)

1. Slowly turn the setpoint screw clockwise until the sensor opens [red flag on indicator or gage shows 3 psi (.2 bar) or less] at the specified setpoint $\pm 2^\circ \text{F}$ (1.1°C). Tighten locknut. One turn on the setpoint screw shifts the setpoint approximately 50°F (28°C).
2. Lower bath temperature at 1°F ($.6^\circ \text{C}$) per minute until the sensor closes (green flag on indicator or gage shows control pressure).
3. Raise bath temperature at 1°F ($.6^\circ \text{C}$) per minute until the sensor opens [red flag on indicator or gage shows 3 psi (.2 bar) or less].
4. If the sensor does not operate within limits, loosen the locknut and **slightly** adjust the setpoint screw to open the sensor at the desired setpoint. Tighten the locknut. Repeat steps 2 and 3 continuing to step 5.
5. Lower bath temperature 10°F (5.6°C) below setpoint and let sensor stabilize for 15 minutes. Check setpoint per step 3. Sensor should open within $\pm 5^\circ \text{F}$ (2.8°C) of setpoint.
6. If sensor does not operate within limits, repeat steps 4 and 5. A continued setpoint shift to higher temperatures indicates a leaking bulb assembly **Not** allowing the sensor to stabilize properly will cause successive lowering shifts in setting.

REVERSE-ACTING (closes vent on increasing temperature)

1. Slowly turn the setpoint screw clockwise until the sensor closes (green flag on indicator or gage shows control pressure) at the specified setpoint $\pm 2^\circ \text{F}$ (1.1°C). Tighten locknut. One turn on the setpoint screw shifts the setpoint approximately 50°F (28°C).
2. Lower the bath temperature at 1°F ($.6^\circ \text{C}$) per minute until the sensor opens [red flag on indicator or gage shows 3 psi (.2 bar) or less].
3. Raise bath temperature at 1°F ($.6^\circ \text{C}$) per minute until the sensor closes (green flag on indicator or gage shows control pressure).
4. If the sensor does not operate within limits, loosen the locknut and **slightly** adjust the setpoint screw to close the sensor at the desired setpoint. Tighten the locknut. Repeat steps 2 and 3 continuing to step 5.
5. Lower bath temperature 10°F (5.6°C) below setpoint and let sensor stabilize for 15 minutes. Check setpoint per step 3. Sensor should close within $\pm 5^\circ \text{F}$ (2.8°C) of setpoint.
6. If sensor does not operate within limits, repeat steps 4 and 5. A continued setpoint shift to higher temperatures indicates a leaking bulb assembly. **Not** allowing the sensor to stabilize will cause successive lowering shifts in setting.

RECOMMENDED TEST SETUPS

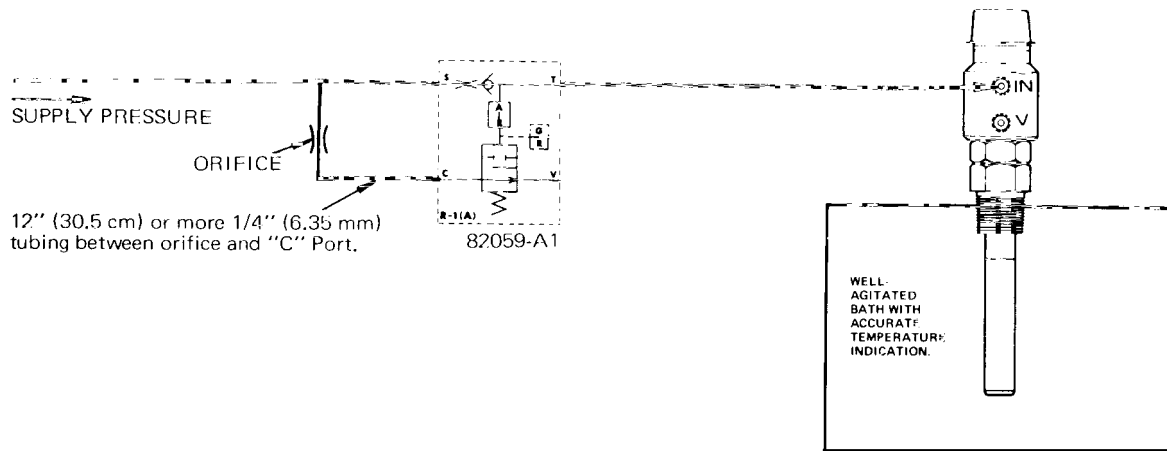
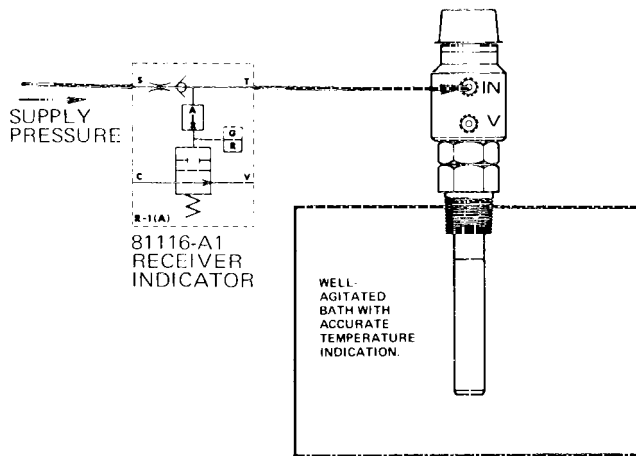
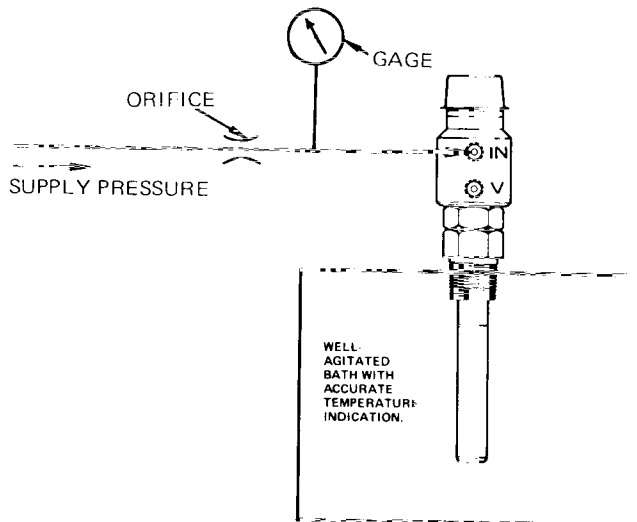

Figure 3

ALTERNATE TEST SETUP



MAINTENANCE (See Figure 5)

WARNING: USE CARE WHEN DISASSEMBLING, SPRING FORCES PRESENT.

CAUTION: Do not subject O-rings or poppet assembly to cleaning fluid, acetone, or any halogenated hydrocarbons such as degrease liquids, etc. Clean only with a soft, dry cloth. Upon reassembly, lubricate O-rings with a non-drying silicone-type lubricant. Metal parts can be cleaned with a non-flammable solvent then dried thoroughly before reassembly.

NOTE: When the poppet is removed/ replaced, a small piece of the lower O-ring on the poppet may be cut from the O-ring as it passes across the "IN" port opening which is drilled into the valve body. To prevent this, a small blunt tool such as an allen wrench can be pressed against the O-ring through this opening as it slides across the opening during poppet removal/ replacement.

DIRECT ACTING (vents on increasing temperature)

For poppet assembly maintenance, remove the protective cover, cap screws and cap, then poppet assembly [spring (detail 8) and spring guide may also be removed if necessary]. Removal of the bulb assembly may be necessary to remove the poppet assembly. If so, remove the bulb assembly per the instructions below. Remove the spring and spring guide. Carefully push (from the valve body end where the bulb assembly was removed) the poppet assembly from the valve body and remove. When reassembling, be careful to reposition all parts correctly.

For bulb, tube, and stem assembly maintenance, remove sensor from bushing or thermowell. Remove bulb assembly. **CAUTION:** Since bulb may require considerable force to remove from housing, be careful to avoid damage to the tube and stem during removal.

WARNING: The tube and stem is held in the bulb by two steel balls under high spring tension. Carefully pull the tube and stem from the bulb in such a manner as to avoid injury to personnel. Note: Extreme care should be used when disassembling to prevent loss of the two steel balls (See Figure 5, detail 13).

The bulb**, or other defective parts, can now be replaced.

To reassemble (refer to Figure 4), position tube in bulb, placing spring in tube. Place and hold the two steel balls in the tube. Preventing the steel balls from entering the bulb, position the stem in the tube and press into the tube until its inward movement is stopped. This can be more easily done by placing the smaller end of the stem against a stationary object and pressing the stem inward. With continued pressure on the stem, slowly allow the tube to continue into the bulb making sure the two steel balls remain properly located in the tube and enter into the bulb. The stem will be "locked" in place when the steel balls are correctly positioned in the bulb.

REVERSE-ACTING (closes vent on increasing temperature)

For poppet assembly maintenance, remove the protective cover, cap screws and cap, then poppet assembly [spring (detail 8), spring guide, stem, spring (detail 14) and tube may also be removed if necessary]. Removal of the bulb

assembly may be necessary to remove the poppet assembly. If so, remove the bulb assembly per the instructions below. Remove the tube, spring (detail 14), stem, spring guide, and spring (detail 8). Carefully push (from the valve body end where the bulb assembly was removed) the poppet assembly from the valve body and remove. When reassembling, be sure to reposition all parts correctly.

For bulb assembly maintenance, remove sensor from bushing or thermowell. Remove bulb assembly.

CAUTION: Bulb may require considerable force to remove from housing.

Bulb assembly**, or other defective parts, can now be replaced.

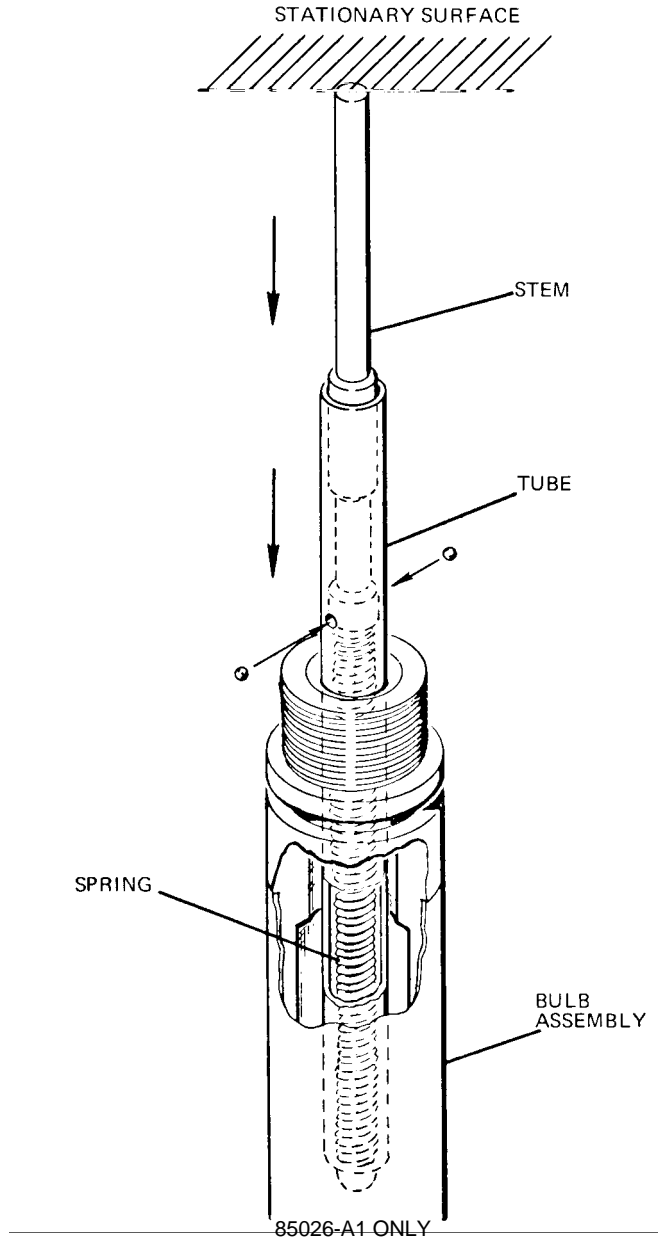
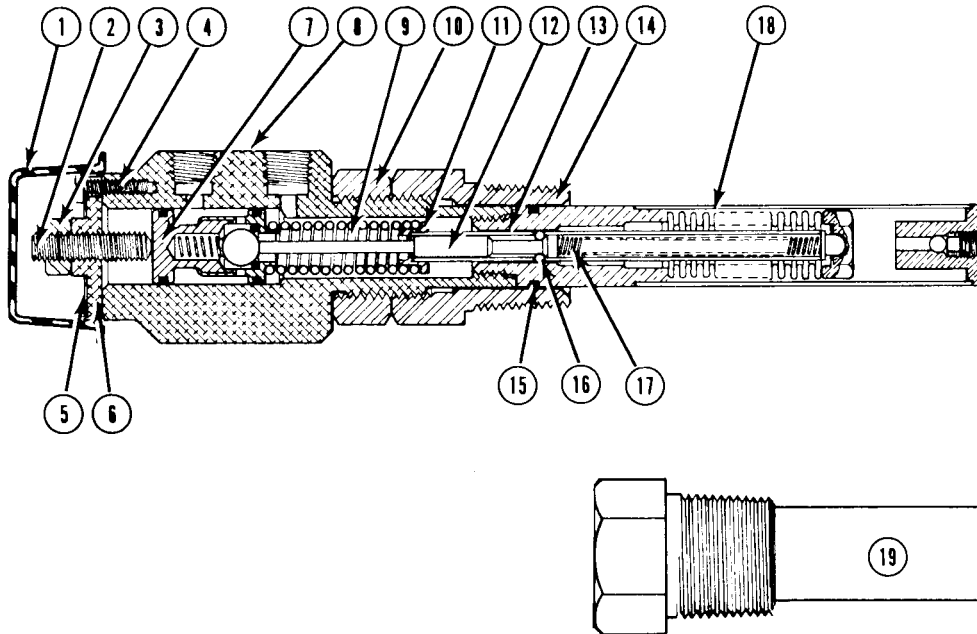

Figure 4

**Bulb threads on both the direct and reverse acting sensors should have an adhesive such as Loctite Sealant "H" applied before reassembly to sensor body.



Part numbers shown in the following table are common for all models of No. 85026-Series.

| Det. No. | No. Req'd | Description | Production Part No. |
|----------|-----------|----------------------|---------------------|
| 1 | 1 | Protective Cap | 20516-H14 |
| 2 | 1 | Adjustment set screw | 36718-E2109 |
| 3 | 1 | Nut | 36602-E1809 |
| 4 | 3 | Screw | 33711-H1109 |
| 5 | 1 | Name plate | 26432-A2 |
| 6 | 1 | Cap | See Tab A |
| *7 | 1 | Poppet Assembly | See Tab. A |
| 8 | 1 | Valve Body | See Tab. A |
| 9 | 1 | Spring | 36156-B1 |
| 10 | 1 | Jam Nut | 36602-G3409 |
| 11 | 1 | Spring Guide | See Tab. A |
| 12 | 1 | Stem | 36157-A1 |
| *13 | 1 | Tube Assembly | 85022-A1 |
| 14 | 1 | Bushing | See Tab. B |
| 15 | 1 | O-ring | See Tab. B |
| 16 | 2 | Balls | See Tab. A |
| 17 | 1 | Spring | 36156-A1 |
| *18 | 1 | Bulb assembly | 85024-B1 |
| 19 | 1 | Thermowell | See Tab. B |

* Recommended Spare Parts.

TABLE A

| Det. No. | Aluminum Body | | St. St. Body | |
|----------|---------------|----------|--------------|----------|
| | Direct | Reverse | Direct | Reverse |
| 6 | 36158-A1 | 36158-A1 | 36158-A2 | 36158-A2 |
| 7 | 85025-A1 | 85025-B1 | 85025-A2 | 85025-B2 |
| 8 | 36162-A1 | 36162-A1 | 36162-A2 | 36162-A2 |
| 11 | 36159-A1 | 36159-A2 | 36159-B1 | 36159-B2 |
| 16 | 23722 | | 23722 | |

TABLE B
(Mounting Accessories)

| Model No. Suffix* | Bushing | O-Ring | Thermowell |
|-------------------|----------|-------------|------------|
| 0001, 0019 | 36166-A1 | 36240-V0015 | |
| 0101, 0119 | | | 85031-A1 |
| 0201, 0219 | | | 85032-A2 |
| 0301, 0319 | | | |

*See Models Available, page 1.

Robertshaw

**Robertshaw Industrial Products Division
1602 Mustang Drive
Maryville, Tennessee 37801
Phone: (865) 981-3100 Fax: (865) 981-3168
<http://www.robertshawindustrial.com>**